

# Quattro 650H/HS

## Four-axis parallel robot achieves high speed and high precision

- Programmable through ACE software and eV+ language, or through the familiar IEC 61131-3 when using ePLC Connect.
- Four-axis arm evenly distributes the load on the robot
- Fast and high-precision conveyance and assembly
- Designed with a high payload to support multi-hand (multi-picking)
- Supports fast Pick & Place on a fast conveyor
- Meets the sanitary standards of the United States Department of Agriculture for prevention of product contamination
- Maximum working diameter 1,300 mm
- Working height 500 mm
- Maximum payload 15 kg
- Weight 117 kg



## Specifications

Product name		Quattro			
Size		650			
Type		H		HS	
IP		Standard	IP65/67	Standard	
Part Number		1721-2600[ ]	1721[ ]-2602[ ]	1721[ ]-2601[ ]	
Number of axes		4			
Mounting		inverted			
Working volume	X,Y axis (stroke)	1300 mm			
	Z axis (stroke)	500 mm			
	theta axis (rotation angle)	0° (fixed) (P30)			
		±46.25° (P31)			
±92.5° (P32)					
±185° (P34)					
Maximum Payload		6 kg (P30: 15 kg)		3 kg (P30: 12 kg)	
Repeatability		±0.10 mm			
Cycle times, sustained, at 20°C ambient	Payload 0.1 kg	0.30 s *1, 0.46 s *2		0.39 s *1, 0.55 s *2	
	Payload 1.0 kg	0.36 s *1, 0.47 s *2		0.41 s *1, 0.58 s *2	
	Payload 2.0 kg	0.37 s *1, 0.52 s *2		0.42 s *1, 0.59 s *2	
	Payload 4.0 kg	0.41 s *1, 0.58 s *2		-	
	Payload 6.0 kg	0.43 s *1, 0.61 s *2		-	
Power Requirements		24 VDC: 11 A (eAIB, SmartController) 200 to 240 VAC: 10 A, single-phase			
Protection	Base	Topside of robot	IP20	IP65	IP66
		Underside of robot	IP65	IP65	IP66
	Platform, Arms		IP67		
Environment Requirements	Ambient Temperature		1 to 40°C		
	Humidity Range		5 to 90% (non-condensing)		
Weight		117 kg			
USDA-Accepted for meat and poultry processing		---	---	Yes	
Basic configuration	Controller		SmartController EX		
	On-board I/O (Input/Output)		12/8		
	Conveyor tracking input		4		
	RS-232C serial communications port		1		
	Programming environment		ACE, ePLC		
	ACE Sight		Yes		
	ePLC Connect		Yes		
ePLC I/O		Yes			
Connectable controller *3		SmartController EX, NJ/NX/NY Series *4			

\*1. Adept cycle, in mm (25/305/25)

\*2. Extended cycle, in mm (25/700/25)

\*3. Choose a controller to suit your application.

\*4. The robot version 2.3.C or later is required to connect with the NJ/NX/NY Series.

# Dimensions

(Unit: mm)

## Quattro 650H/HS

Note: The figure shows the HS type.

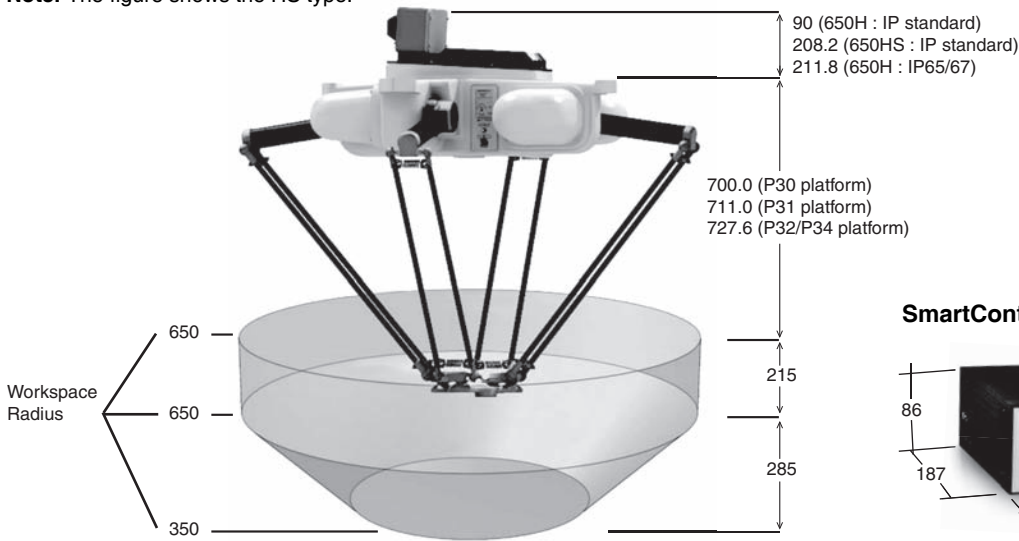





## Front panel



## SmartController EX



Four choices of platform offer different ranges of rotation.

Appearance				
Type	P30	P31	P32	P34
Rotation angle	No rotation	±46.25°	±92.5°	±185°
Maximum Payload	H: 15 kg, HS: 12 kg	H: 6 kg, HS: 3 kg	H: 6 kg, HS: 3 kg	H: 6 kg, HS: 3 kg

Note: The platform appearances of the H type are shown above. The platform of the HS type is made of stainless steel.

# Robot Parts Code and Bundled Accessories

Type	Quattro with EX Controller			Quattro Add-On		
	Standard (H)	Standard (HS)	IP65/67	Standard (H)	Standard (HS)	IP65/67
Quattro P30	17214-26000	17214-26010	17214-26020	17213-26000	17213-26010	17213-26020
Quattro P31	17214-26001	17214-26011	17214-26021	17213-26001	17213-26011	17213-26021
Quattro P32	17214-26002	17214-26012	17214-26022	17213-26002	17213-26012	17213-26022
Quattro P34	17214-26004	17214-26014	17214-26024	17213-26004	17213-26014	17213-26024
Overview	Robot + eAIB+ SmartController EX + required connection cables			Robot + eAIB + required connection cables		
Purpose	Typical for use in single robot system and multi-robot systems.			Typically added to systems with an existing SmartController EX to create multi-robot systems		
Bundled Accessories	<ul style="list-style-type: none"> <li>SmartController EX (09200-000)</li> <li>XSYS cable, 4.5 m/15 ft (11585-000)</li> <li>1394 latch cable, 4.5 m/15 ft (13632-045)</li> <li>Front panel kit (92546-10358)</li> <li>eV+ license to connect to controller (14529-103)</li> </ul>	<ul style="list-style-type: none"> <li>SmartController EX (09200-000)</li> <li>XSYS cable, 4.5 m/15 ft (11585-000)</li> <li>1394 latch cable, 4.5 m/15 ft (13632-045)</li> <li>Front panel kit (92546-10358)</li> <li>eV+ license to connect to controller (14529-103)</li> <li>Cable Seal Kit (09564-000)</li> </ul>	<ul style="list-style-type: none"> <li>SmartController EX (09200-000)</li> <li>XSYS cable, 4.5 m/15 ft (11585-000)</li> <li>1394 latch cable, 4.5 m/15 ft (13632-045)</li> <li>Front panel kit (92546-10358)</li> <li>eV+ license to connect to controller (14529-103)</li> <li>Cable Seal Kit (08765-000)</li> </ul>	<ul style="list-style-type: none"> <li>XSYS cable, 4.5 m/15 ft (11585-000)</li> <li>DB9 splitter (00411-000)</li> <li>1394 latch cable, 4.5 m/15 ft (13632-045)</li> <li>eV+ license to connect to controller (14529-103)</li> </ul>	<ul style="list-style-type: none"> <li>XSYS cable, 4.5 m/15 ft (11585-000)</li> <li>DB9 splitter (00411-000)</li> <li>1394 latch cable, 4.5 m/15 ft (13632-045)</li> <li>eV+ license to connect to controller (14529-103)</li> <li>Cable Seal Kit (09564-000)</li> </ul>	<ul style="list-style-type: none"> <li>XSYS cable, 4.5 m/15 ft (11585-000)</li> <li>DB9 splitter (00411-000)</li> <li>1394 latch cable, 4.5 m/15 ft (13632-045)</li> <li>eV+ license to connect to controller (14529-103)</li> <li>Cable Seal Kit (08765-000)</li> </ul>

# Quattro 800H/HS

## Four-axis parallel robot achieves high speed and high precision

- Programmable through ACE software and eV+ language, or through the familiar IEC 61131-3 when using ePLC Connect
- Four-axis arm evenly distributes the load on the robot
- Fast and high-precision conveyance and assembly
- Designed with a high payload to support multi-hand (multi-picking)
- Supports fast Pick & Place on a fast conveyor
- Meets the sanitary standards of the United States Department of Agriculture for prevention of product contamination
- Maximum working diameter 1,600 mm
- Working height 500 mm
- Maximum payload 10 kg
- Weight 117 kg



## Specifications

Product name		Quattro			
		800		HS	
Size		H			
Type		Standard	IP65/67	Standard	
IP					
Part Number		1721[ ]-2630[ ]	1720[ ]-2632[ ]	1721[ ]-2631[ ]	
Number of axes		4			
Mounting		inverted			
Working volume	X,Y axis (stroke)	1600 mm			
	Z axis (stroke)	500 mm			
	theta axis (rotation angle)	0° (fixed) (P30)			
		±46.25° (P31)			
±92.5° (P32)					
Maximum Payload		4 kg (P30:10 kg)	1 kg (P30: 7 kg)		
Repeatability		±0.10 mm			
Cycle times, sustained (at 20°C ambient)	Payload 0.1 kg	0.33 s *1, 0.48 s *2		-	
	Payload 1.0 kg	0.38 s *1, 0.50 s *2		0.45 s *1, 0.62 s *2	
	Payload 2.0 kg	0.40 s *1, 0.55 s *2		-	
	Payload 4.0 kg	0.45 s *1, 0.62 s *2		-	
Power Requirements		24 VDC: 11 A (eAIB, SmartController) 200 to 240 VAC: 10 A, single-phase			
Protection	Base	Topside of robot	IP20	IP65	IP66
		Underside of robot	IP65	IP65	IP66
	Platform, Arms	IP67			
Environment Requirements	Ambient Temperature	1 to 40°C			
	Humidity Range	5 to 90% (non-condensing)			
USDA-Accepted for meat and poultry processing		---	---	Yes	
Weight		117 kg			
Basic configuration	Controller	SmartController EX			
	On-board I/O (Input/Output)	12/8			
	Conveyor tracking input	4			
	RS-232C serial communications port	3			
	Programming environment	ACE, ePLC			
	ACE Sight	Yes			
	ePLC Connect	Yes			
Connectable controller *3		SmartController EX, NJ/NX/NY Series *4			

\*1. Adept cycle, in mm (25/305/25)

\*2. Extended cycle, in mm (25/700/25)

\*3. Choose a controller to suit your application.

\*4. The robot version 2.3.C or later is required to connect with the NJ/NX/NY Series.

# Dimensions

(Unit: mm)

## Quattro 800H/HS



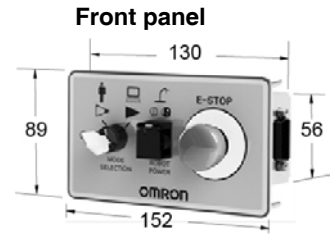
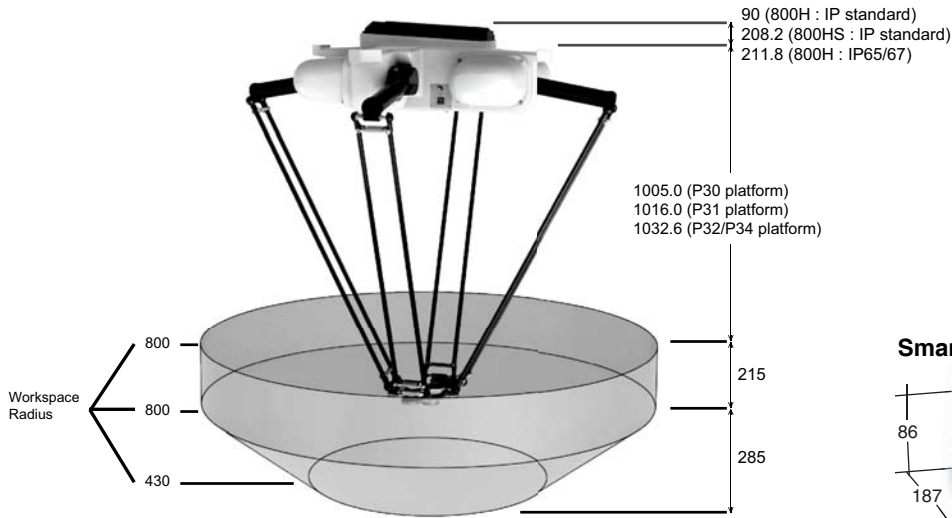

Note: The figure shows the H type.

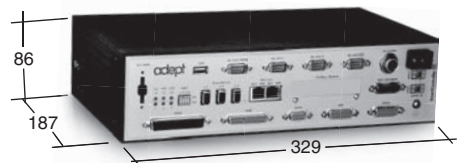

## SmartController EX



Four choices of platform offer different ranges of rotation.

Appearance				
Type	P30	P31	P32	P34
Rotation angle	No rotation	±46.25°	± 92.5°	±185°
Maximum Payload	H: 10 kg, HS: 7 kg	H: 4 kg, HS: 1 kg	H: 4 kg, HS: 1 kg	H: 4 kg, HS: 1 kg

Note: The platform appearances of the H type are shown above. The platform of the HS type is made of stainless steel.

## Robot Parts Code and Bundled Accessories

Type	Quattro with EX Controller			Quattro Add-On		
	Standard (H)	Standard (HS)	IP65/67	Standard (H)	Standard (HS)	IP65/67
Quattro P30	17214-26300	17214-26310	17214-26320	17213-26300	17213-26310	17213-26320
Quattro P31	17214-26301	17214-26311	17214-26321	17213-26301	17213-26311	17213-26321
Quattro P32	17214-26302	17214-26312	17214-26322	17213-26302	17213-26312	17213-26322
Quattro P34	17214-26304	17214-26314	17214-26324	17213-26304	17213-26314	17213-26324
Overview	Robot + eAIB+ SmartController EX + required connection cables			Robot + eAIB + required connection cables		
Purpose	Typical for use in single robot system and multi-robot systems.			Typically added to systems with an existing SmartController EX to create multi-robot systems		
Bundled Accessories	<ul style="list-style-type: none"> <li>SmartController EX (09200-000)</li> <li>XSYS cable, 4.5 m/15 ft (11585-000)</li> <li>1394 latch cable, 4.5 m/15 ft (13632-045)</li> <li>Front panel kit (92546-10358)</li> <li>eV+ license to connect to controller (14529-103)</li> </ul>	<ul style="list-style-type: none"> <li>SmartController EX (09200-000)</li> <li>XSYS cable, 4.5 m/15 ft (11585-000)</li> <li>1394 latch cable, 4.5 m/15 ft (13632-045)</li> <li>Front panel kit (92546-10358)</li> <li>eV+ license to connect to controller (14529-103)</li> <li>Cable Seal Kit (09564-000)</li> </ul>	<ul style="list-style-type: none"> <li>SmartController EX (09200-000)</li> <li>XSYS cable, 4.5 m/15 ft (11585-000)</li> <li>1394 latch cable, 4.5 m/15 ft (13632-045)</li> <li>Front panel kit (92546-10358)</li> <li>eV+ license to connect to controller (14529-103)</li> <li>Cable Seal Kit (08765-000)</li> </ul>	<ul style="list-style-type: none"> <li>XSYS cable, 4.5 m/15 ft (11585-000)</li> <li>DB9 splitter (00411-000)</li> <li>1394 latch cable, 4.5 m/15 ft (13632-045)</li> <li>eV+ license to connect to controller (14529-103)</li> <li>Cable Seal Kit (09564-000)</li> </ul>	<ul style="list-style-type: none"> <li>XSYS cable, 4.5 m/15 ft (11585-000)</li> <li>DB9 splitter (00411-000)</li> <li>1394 latch cable, 4.5 m/15 ft (13632-045)</li> <li>eV+ license to connect to controller (14529-103)</li> <li>Cable Seal Kit (08765-000)</li> </ul>	<ul style="list-style-type: none"> <li>XSYS cable, 4.5 m/15 ft (11585-000)</li> <li>DB9 splitter (00411-000)</li> <li>1394 latch cable, 4.5 m/15 ft (13632-045)</li> <li>eV+ license to connect to controller (14529-103)</li> <li>Cable Seal Kit (08765-000)</li> </ul>